

4341 M60

4 CYLINDERS IN LINE - DIESEL CYCLE

44 kW (60 HP) @ 3600 rpm (A1)

Specifications

Thermodynamic cycle		Diesel 4 stroke
Air intake		NA
Arrangement		4L
Bore x Stroke	mm	88 x 90.4
Total displacement	l	2.199
Valves per cylinder	n.	2
Cooling system		liquid
Direction of rotation (viewed facing flywheel)		CCW
Engine management		mechanical
Injection system		mechanical pump

Electrical system

Voltage	V	12
---------	---	----

Standard configuration

Flywheel housing	type	SAE
Flywheel size	inch	alignment, flexible couplig Ø 151.5 mm
Air filter		dry
Turbocharger		-
Heat exchanger		tube type
Exhaust cooled elbow		stainless steel Ø 60 mm
Water charge tank		included
Fuel filter	n.	1 - right side
Fuel prefilter		-
Fuel pump		included
Oil filter	n.	1 - left side
Oil sump		pressed steel with corrosion inhibiting treatment
Oil vapours blow-by circuit		yes
Oil heat exchanger		-
Oil filler		on timing cover frontward
Starting motor		12V - 2.2kW
Alternator		12V - 65A
Engine stop device		electrical excitation
Wiring harness		wiring harness and electrical panel
Painting	color	white "ICE"

Not included in the standard configuration

Battery - minimum capacity recommended		88 Ah
Battery - minimum cold cranking capacity recommended		-

FPT OFFERS THE WIDEST AVAILABILITY OF ENGINE BUILD OPTIONS TO CUSTOMER SPECIFIC REQUIREMENTS WITHIN THE ENGINE SUPPLY. TO FIND OUT MORE ABOUT THE CONFIGURATIONS AND ACCESSORIES WHICH ARE AVAILABLE, CONTACT THE FPT SALES NETWORK.

Rating type		A1
Maximum power [*]	kW(HP)	44 (60)
At speed	rpm	3600
Maximum no load governed speed at max rating	rpm	3850
Minimum idling speed	rpm	850 ± 50
Mean piston speed at rated speed	m/s	10.8
BMEP at max power	kg/cm ²	7.07
Specific fuel consumption at full load (best value)	g/kWh @ rpm	254 @ 2100
Oil consumption at max rating	(% of fuel cons.)	≤ 0.2
Minimum starting temperature without auxiliaries	°C	-10°
Oil and oil filter maintenance interval for replacement	hours	250 oil / 125 filters

* **Net Power** at flywheel according to ISO 3046/1, after 50 hours running, Fuel Diesel EN 590. Power tolerance 5%.

Test conditions: ISO 3046/1, 25 °C air temperature, 100 kPa atmospheric pressure, 30 % relative humidity .

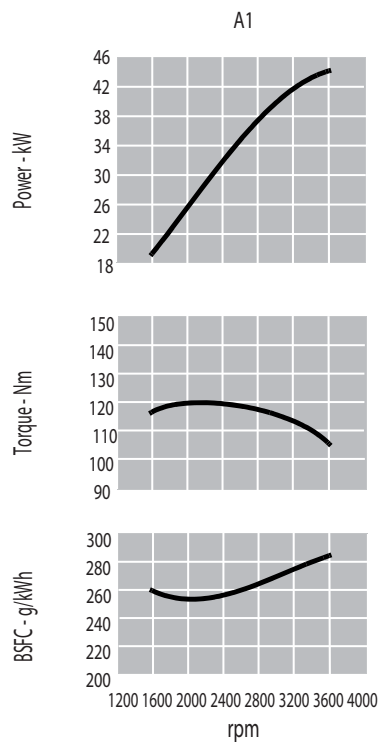

A1 = High performance crafts:
 Full throttle operation restricted within 10% of total use period.
 Cruising speed at engine rpm <90% of rated speed setting - Maximum useage 300 hours per year.

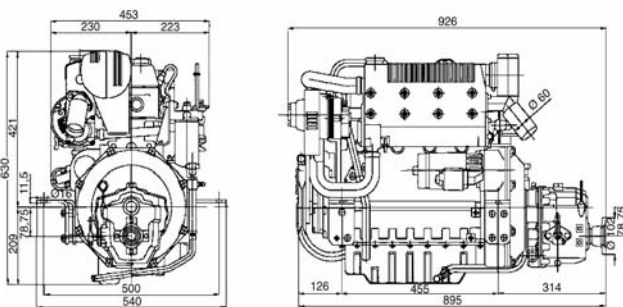

Dry weight (without marine gear) = 232 kg.

Publication P3D064005E - 03.11
 Specifications subject to change without notice.
 Illustrations may include optional equipment.